

R490 - Amplificateur de débit d'air comprimé, piloté en pression

Description	The volume booster amplifies the volume at a 1:1 ratio of pilot pressure to outlet pressure. The booster is a rugged precision instrument with key features providing reliable, efficient and stable operation. Very low deadband between the operation of the supply valve and exhaust valve providing excellent pressure control. High capacity exhaust valve provides efficient dynamic reverse flow characteristics. Pressure balanced supply valve prevents changes in control characteristics when supply pressure changes. Damped diaphragm control chamber provides stable operation and protects valves from damaging oscillation under high flow conditions.		
Media	compressed air or non-corrosive gases	Supply pressure	max. 17 bar
Pilot pressure Accuracy	max. 10 bar; pilot port G $\frac{1}{4}$ at supply pressure variation of 7 bar: < 7 mbar pressure deviation response sensitivity: 2.5 mbar	Relieving function	relieving
Air consumption	max. 3 l/min subject to outlet pressure	Mounting position	any
Relief capacity	2800 l/min at 0.35 bar overpressure above setpoint of 1.5 bar		
Gauge port	$\frac{1}{4}$ " NPT on both sides of the body, screw plugs supplied		
Temperature range	-40 °C to 93 °C / -40 °F to 199 °F		
Material	Body: aluminium die-cast Diaphragm: NBR/Buna-N on Polyester, optionally FKM Inner valve: zinc-plated steel, optionally stainless steel		

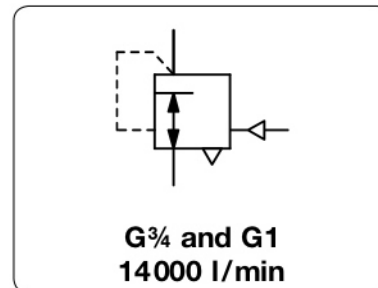

Dimensions			K _v -value	Flow rate	Connection thread	Supply pressure	Pressure range	Order number
A	B	C						
mm	mm	mm	(m ³ /h)	m ³ /h*1	l/min*1	G	max. bar	signal : outlet

Booster		transmission ratio 1:1, supply pressure max. 17 bar, relieving, with constant bleed						Order number	
143	188	44	9	850	14 100	G $\frac{3}{4}$	17	0 ... 10	R490-06
143	188	44	9	850	14 100	G1	17	0 ... 10	R490-08



R490

Special options, add the appropriate letter

NPT	connection thread	R490-0 . N
external feedback	with connection thread G $\frac{1}{4}$	R490-0 . X27
FKM elastomer		R490-0 . V
inner parts SST	all	R490-0 . S

Accessories, enclosed

pressure gauge	Ø 63 mm, 0...*2 bar, G $\frac{1}{4}$	MA6302-..*2
-----------------------	--------------------------------------	--------------------

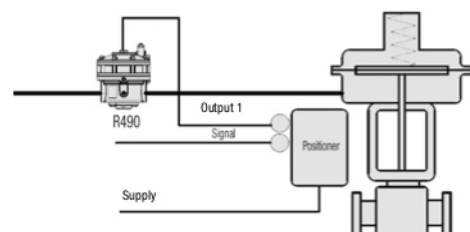

Volume booster with single acting positioner and diaphragm actuator

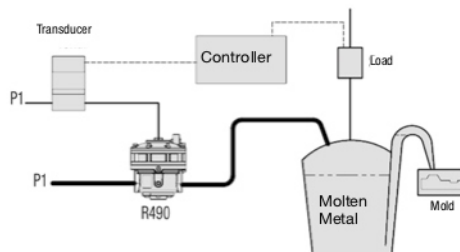

Volume booster: casting implements

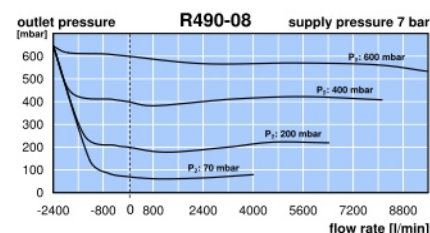
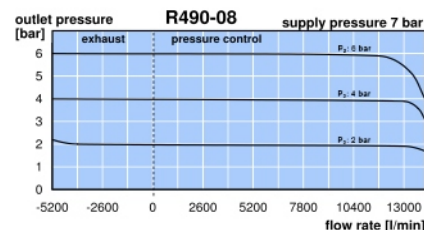
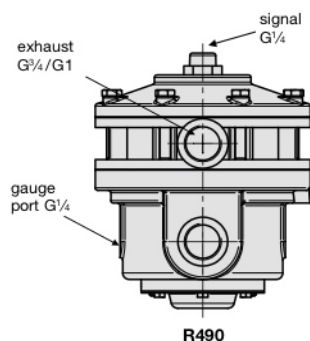
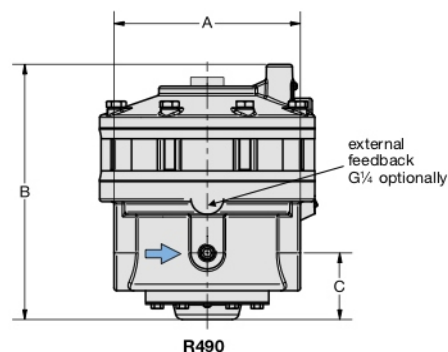

*1 at 7 bar supply pressure and 1.4 bar outlet pressure
*2 02 = 0...2.5 bar, 04 = 0...4 bar, 06 = 0...6 bar, 10 = 0...10 bar