

Filtere sub-micronique pour air comprimé et gaz neutres, filtration à charbon actif

G50

Description	The filter separates oil, water and solid impurities from compressed air or non-corrosive gases. It is resistant to mineral and synthetic oils.
Filter element	Fabric of borosilicate fibre A 901 with high-volume fiberglass bed. Coalescing effect based on Brownian motion. With stainless steel jacket and internal draining layer. An arrow indicates flow from inside to outside.
Filtration efficiency	99.99% based on 3 µm particle size, Δp= 0.02/0.07 bar*, see special options for further filters
Service life	Large filter volume through folding makes for exceptionally long service life and high capacity for collection of solid particles with low differential pressure.
Filter change	The filter must be changed as from 0.35 bar differential pressure or after one year at the latest.
Drainage	manual drain as standard
Operating pressure	max. 50 bar
Temperature range	1 °C to 80 °C / 34 °F to 176 °F at coalescing filter 1 °C to 40 °C / 34 °F to 104 °F at activated carbon filter
Material	Body: chromated and powder-coated Elastomer: NBR/Buna-N Ball valve: stainless steel

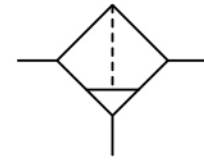

50 bar, up to G2
0.01 / 1 / 3 µm

Dimensions			Bowl	Flow	Connection	Order
A	B	C	Design	rate *2	thread	number
mm	mm	mm	made of / with	m ³ /h	G	

High pressure filter up to 50 bar			with manual drain, 99.99% bei 3 µm			G . /50		
61	200	186	aluminium/	0,17	75	1250	G¼	G 2/50V
87	245	224	manual drain	0,50	125	2080	G¼	G 3/50V
87	245	224		0,50	175	2920	G¾	G 5/50V
87	315	294		0,60	250	4170	G½	G 7/50V
130	350	307		1,60	450	7500	G¾	G 9/50V
130	450	407		2,50	750	12500	G1	G11/50V
130	525	482		3,00	1175	19600	G1½	G12/50V
130	755	712		4,50	1750	29100	G1½	G13/50V
164	735	687		6,00	2600	43300	G2	G14/50V



G7/50V

Special options, add the appropriate letter

	Filtration efficiency	Residual oil content	Δp*1	
1 µm filter element	99.9999%	< 0.5 mg/m ³	0.03/0.10 bar	G...ZP
0.01 µm filter element	99.99999%	< 0.01 mg/m ³	0.06/0.15 bar	G...XP
0.01 µm filter element	99.99999%	< 0.001 mg/m ³	0.12/0.28 bar	G...XP4
activated carbon		< 0.003 mg/m ³	0.03 bar	G...A
differential press. gauge			not for G2/50 V	G...D
without manual drain				G...H



G7/50VD
with differential pressure gauge

Accessories

mounting bracket set	made of steel	for part no. G2	BW00-09
		for part no. G3 to G7	BW00-10
		for part no. G9 to G13	BW00-11

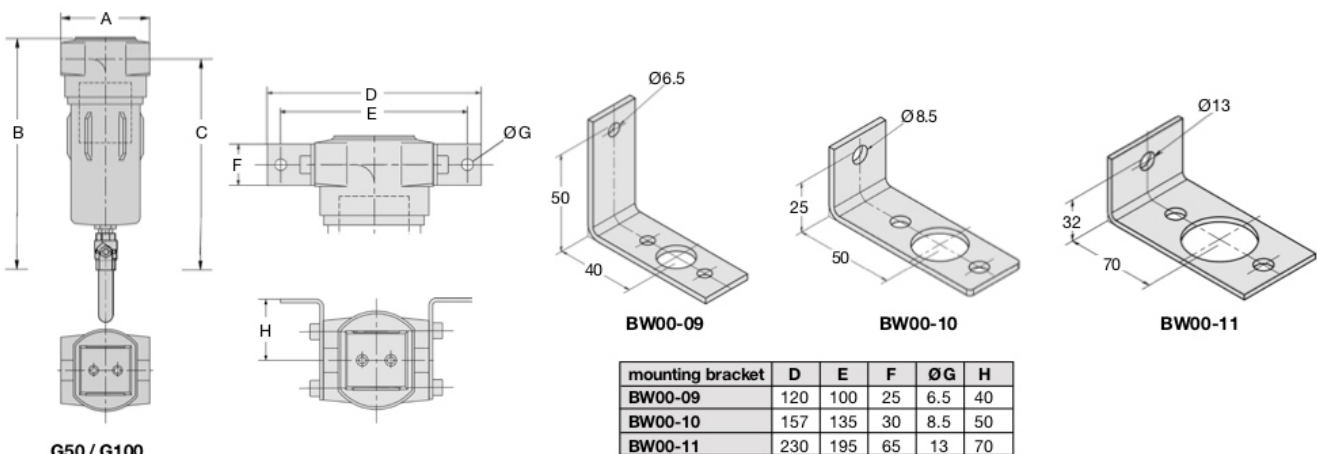

G50 / G100

*1 pressure drop, dry/wetted

*2 at max. operating pressure

Filtre sub-micronique pour air comprimé et gaz neutres, filtration à charbon actif

G100

Description	The filter separates oil, water and solid impurities from compressed air or non-corrosive gases. It is resistant to mineral and synthetic oils.
Filter element	Fabric of borosilicate fibre A 901 with high-volume fiberglass bed. Coalescing effect based on Brownian motion. With stainless steel jacket and internal draining layer. An arrow indicates flow from inside to outside.
Filtration efficiency	99.99% based on 3 µm particle size, Δp= 0.02/0.07 bar*, see special options for further filters
Service life	Large filter volume through folding makes for exceptionally long service life and high capacity for collection of solid particles with low differential pressure.
Filter change	The filter must be changed as from 0.35 bar differential pressure or after one year at the latest.
Drainage	manual drain as standard
Operating pressure	max. 50 bar or 100 bar
Temperature range	1 °C to 80 °C / 34 °F to 176 °F at coalescing filter 1 °C to 40 °C / 34 °F to 104 °F at activated carbon filter
Material	Body: chromated and powder-coated cast aluminium at G½ powder-coated steel of G¾ to G1½ bar Elastomer: NBR/Buna-N Ball valve: stainless steel

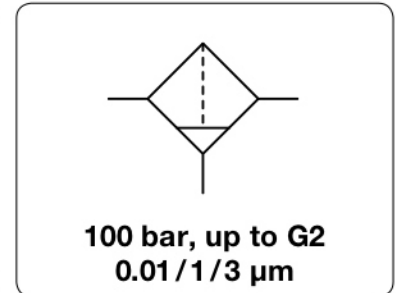

Dimensions			Bowl	Flow	Connection	Order
A	B	C	Design	Capacity	rate *2	number
mm	mm	mm	made of / with	l	m³/h	l/min

High pressure filter up to 100 bar						with manual drain, 99.99% bei 3 µm	G . /100	
90	330	305	aluminium/	0,35	120	2000	G¼	G 3/100V
90	330	305	manual drain	0,35	180	3000	G¾	G 5/100V
90	395	370		0,50	300	5000	G½	G 7/100V
116	445	420	steel/	1,40	550	9100	G¾	G 9/100V
116	530	505	manual drain	2,00	850	14100	G1	G11/100V
125	640	607		2,90	1175	19600	G1½	G12/100V
125	900	867		4,30	1750	29100	G1½	G13/100V



G7/100V

Accessories

mounting bracket set made of steel

for part no. G2 **BW00-09**
for part no. G3 to G7 **BW00-10**
for part no. G9 to G13 **BW00-11**



G7/100VD
with differential pressure gauge

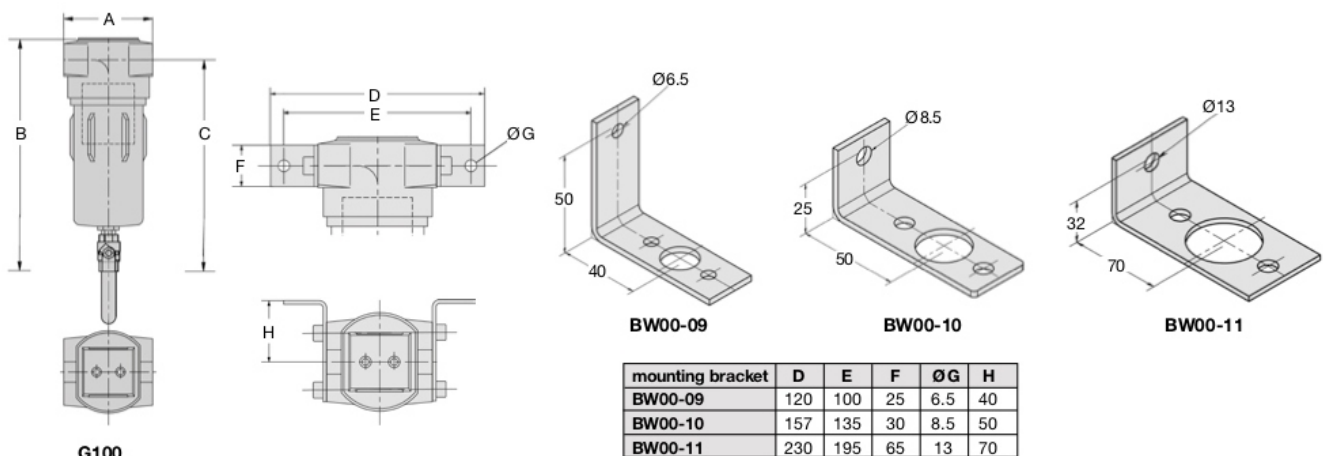

*1 pressure drop, dry/wetted

*2 at max. operating pressure

Filtre sub-micronique pour air comprimé et gaz neutres, filtration à charbon actif

G350

Description	The filter separates oil, water and solid impurities from compressed air or non-corrosive gases. It is resistant to mineral and synthetic oils.
Filter element	Fabric of borosilicate fibre A 901 with high-volume fiberglass bed. Coalescing effect based on Brownian motion. With stainless steel jacket and internal draining layer. An arrow indicates flow from inside to outside.
Filtration efficiency	99.99% based on 3 µm particle size, Δp= 0.02/0.07 bar*, see special options for further filters
Service life	Large filter volume through folding makes for exceptionally long service life and high capacity for collection of solid particles with low differential pressure.
Filter change	The filter must be changed as from 0.35 bar differential pressure or after one year at the latest.
Drainage	manual drain as standard
Operating pressure	max. 350 bar
Temperature range	1 °C to 80 °C / 34 °F to 176 °F at coalescing filter 1 °C to 40 °C / 34 °F to 104 °F at activated carbon filter
Material	Body: chromated and powder-coated cast aluminium at sizes G¾ to G½, powder-coated steel at sizes G¾ to G1½ Elastomer: NBR/Buna-N Needle valve: stainless steel

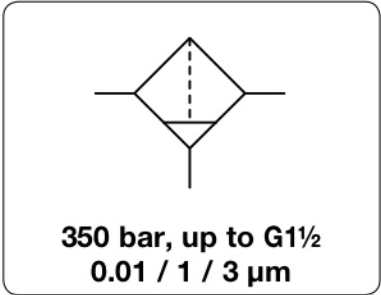

Dimensions			Bowl	Flow	Connection	Order
A	B	C	Design	rate *2	thread	number
mm	mm	mm	made of/with	m³/h	G	

High pressure filter up to 350 bar							with manual drain, 99.99% at 3 µm	G . /350
80	355	330	aluminium/	0,35	365	6080	G½	G 3/350V
80	355	330	manual drain	0,35	501	8350	G½	G 5/350V
80	420	395		0,52	776	12930	G½	G 7/350V
116	455	430	steel/	1,33	1035	17250	G¾	G 9/350V
116	540	515	manual drain	2,09	1852	30870	G1	G11/350V
125	655	622		2,81	2816	46930	G1½	G12/350V
125	910	877		4,41	4261	71020	G1½	G13/350V



Special options, add the appropriate letter

	Filtration efficiency	Residual oil content	Δp*1	
1 µm filter element	99.9999%,	< 0.5 mg/m³,	0.03/0.10 bar	G.. /... ZP
0.01 µm filter element	99.99999%,	< 0.01 mg/m³,	0.06/0.15 bar	G.. /... XP
0.01 µm filter element	99.99999%,	< 0.001 mg/m³,	0.12/0.28 bar	G.. /... XP4
activated carbon		< 0.003 mg/m³	0.03 bar	G.. /... A
differential press. gauge				G.. /... D
without manual drain				G.. /... H

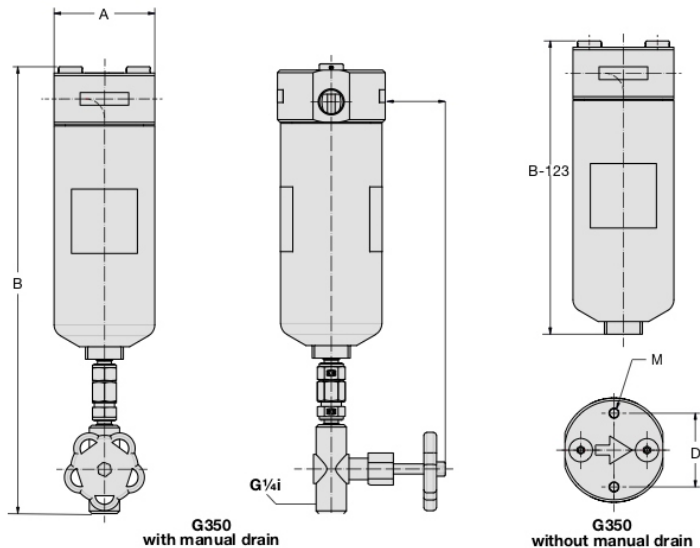

TYP	D	M
G3	100	M8x20
G5	115	M8x20
G7	185	M8x20
G9	170	M10x25
G11	270	M10x25
G12	365	M10x25
G13	560	M10x25

*1 pressure drop, dry/wetted

*2 at max. operating pressure

