

Precision Vacuum Regulator

R250

Description	Regulator for high precision in vacuum and pressure range.	
Flow rate	70 l/min / 2.5 scfm at -0.98 bar vacuum	
K_v-value	0.7 (m ³ /h)	
Sensitivity	2 mbar	
Supply pressure	max. 17 bar	
Temperature range	-20 °C to 70 °C / 160 °F operating temperature, -20 °C to 90 °C / 200 °F operating temperature for Viton	-40 °C to 90 °C storage temperature
Materials	Body: aluminum die-casting Diaphragm: NBR and Dacron	Inner valve: stainless steel and brass

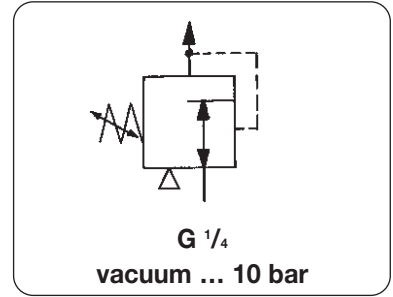

Dimensions			Flow rate	Connection thread	Pressure range	Order number
height	width	depth				
mm	mm	mm	l/min*	G	bar	

Vacuum regulator G 1/4			K _v -value: 0.7 (m ³ /h)	R250		
184	76	76	70	G 1/4	-1...+0.14 bar	R250 - 020
184	76	76	70	G 1/4	-1...+0.7 bar	R250 - 02A
184	76	76	70	G 1/4	-1...+2.0 bar	R250 - 02B
184	76	76	70	G 1/4	-1...+7.0 bar	R250 - 02C
184	76	76	70	G 1/4	-1...+10 bar	R250 - 02D



R250

Special options add the appropriate letter

tamper-proof cap		T	R250 - 02. T
mounting bracket	SA - R230	X	R250 - 02. X

Accessories

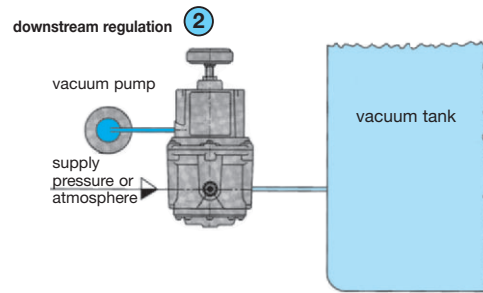
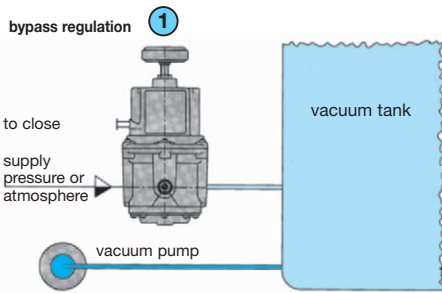
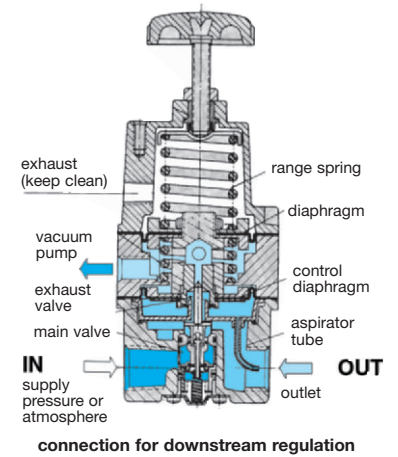
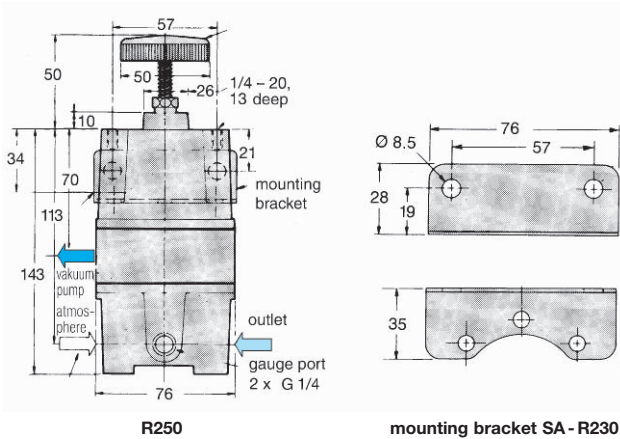

Notice:
A filter is recommended on the atmospheric or pressure side.

1 Bypass regulation
Upstream installation is preferred when rapid exhaust of a vessel or system is required.

2 Downstream regulation
The regulator is located between the pump and the vessel. The vacuum pump is energy-saving and it is easy to fill the vessel to its optimal level with pressure or vacuum.

* to -0.98 bar.

For your information:	1 bar: 14.8 psi	1 mbar: 10 mm H ₂ O	1 mbar: 0.75 mmHg	1 mbar: 0.40" H ₂ O	1 l/min: 0.035 scfm	1 mm: 0.039 inch
	1 psi: 0.069 bar	1 mm H ₂ O: 0.1 mbar	1 mmHg: 1.33 mbar	1" H ₂ O: 2.5 mbar	1 scfm: 28.3 l/min	1 inch: 25.4 mm

Order example:
R250 - 020