

# High Precision Pressure Regulator, Accuracy 5 mbar

# Type Manostat

<b>Description</b>	Regulator of proven reliability and durability designed for precise pressure regulation in the event of disturbances in flow, supply pressure and temperature. With high relieving capability, excellent setting sensitivity and suitable for operation in dead end conditions.		
<b>Media</b>	Air or dry gases, oil-free and filtered to over 25 µm.		
<b>Supply pressure</b>	max. 10 bar / 150 psi	min. 0.2 bar / 3 psi above outlet pressure.	53.1001.7X max. 2 bar / 30 psi
<b>Flow capacity</b>	280 l/min / 10 scfm		
<b>Relieving</b>	Excellent relieving capability improving sensitivity and flow, recommended for balancer.		
<b>Air consumption</b>	0.14 - 1.7 bar: 0.3 l/min / 0.01 scfm, 0.14 - 8 bar: 0.6 l/min / 0.02 scfm		
<b>Handwheel</b>	Pressure adjusting handwheel, mounting in any direction, mounting nut supplied.		
<b>Gauge port</b>	1/4" on both sides of body		
<b>Accuracy</b>	Pressure fluctuation at mid-range of outlet: 0.1% at 0.14 - 1.7bar, 0.05% at 0.14 - 4bar, 0.02% at 0.14 - 8bar		
<b>Hysteresis</b>	< 0.05% setting at mid-range of outlet		
<b>Sensitivity</b>	< 0.3 mbar / 0.05 psi		
<b>Flow effect</b>	< 0.7 mbar / 0.01 psi inlet / relief at 1% flow		
<b>Temperature range</b>	-20 °C to 70 °C / -4 °F to 160 °F		
<b>Materials</b>	Zinc die-casting passivated and epoxy painted,	beryllium copper capsule,	NBR (Buna N) diaphragm

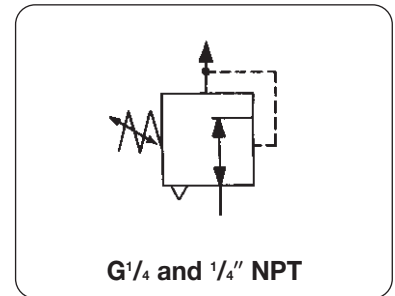

Description	Connection thread	Pressure range bar	Order number
	G <sup>1</sup> / <sub>4</sub> " and 1/4" NPT	bar	

Precision pressure regulator	flow 280 l/min precision 5 mbar	K <sub>v</sub> : 0.15 (m <sup>3</sup> /h) supply max. 10 bar*	Manostat
standard	G <sup>1</sup> / <sub>4</sub>	0.05...0.6	53.1001.7X
		0.14...1.7	53.1002.4X
		0.14...4	53.1002.5X
		0.14...8	53.1002.6X
with gear 6:1	1/4" NPT	0.05...0.6	53.1001.00
		0.14...1.7	53.1002.00
		0.14...4	53.1003.00
		0.14...8	53.1004.00
tapped exhaust 1/8" NPT	1/4" NPT	0.14...1.7	53.1002.96
		0.14...4	53.1003.96
		0.14...8	53.1004.96
		0.14...1.7	53.1302.00
		0.14...4	53.1303.00
		0.14...8	53.1304.00



53.1002.6X

Special options	add the appropriate letter	Accessories
pressure gauge	Ø 50, loose	G 53.1... .G
tamper-proof cap	53.ZZ00.08 threaded over adjusting screw	T 53.1... .T
mounting bracket	53.ZZ00.07 loose	X 53.1... .X
diaphragm repair kit	with spring and seals	0.14 at 1.7 53.1000.95R
		0.14 at 4 53.1000.99R
		0.14 at 8 53.1000.98R

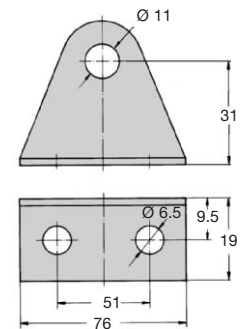
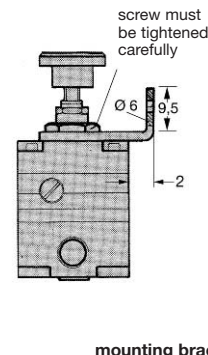
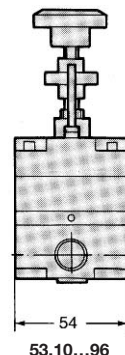
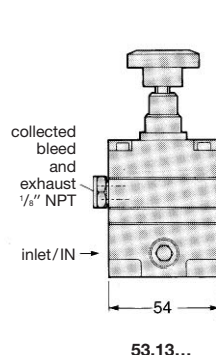
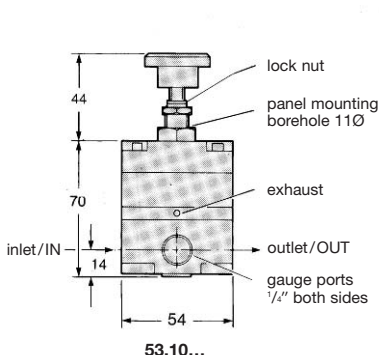
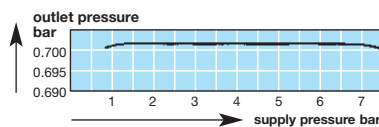
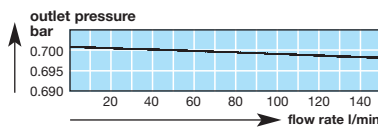
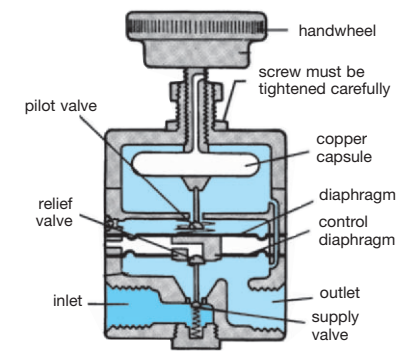

\* 53.1001.7X supply pressure max. 2 bar / 30 psi

<b>For your information:</b>	1 bar: 14.8 psi	1 l/min: 0.035 scfm	1 mm: 0.039 inch
	1 psi: 0.069 bar	1 scfm: 28.3 l/min	1 inch: 25.4 mm

**Order example:**  
53.1004.00