

### Description

Volume boosting air-relays permit precise remote control of regulated pressures with minimal air usage. The normal operating mode produces a direct 1:1 relationship between signal and regulated pressure. Provision can also be made for positive or negative bias between pilot signal and outlet pressure. Manually adjusted differential pressure between pilot signal and outlet pressure remains constant. Air or dry gases, oil-free and filtered to over 25 µm.

**Differ. pressure reg. Media**  
 max. 10 bar / 150 psi at least 0.2 bar / 3 psi above outlet pressure

**Flow capacity**  
 280 l/min / 10 scfm, at 7 bar / 100 psi supply and 1.4 bar / 20 psi set pressure

**Relieving**  
 Excellent with respect to flow and sensitivity, exhaust valve 6 times bigger than main valve

**Air consumption**  
 0.14 - 1.7 bar: 0.5 l/min / 1 scfh, 0.14 - 4 bar: 1 l/min / 2 scfh, 0.14-8 bar: 2 l/min / 4 scfh

**Accuracy**  
 Pressure change at mid-range outlet: 0.1% at 0.14-1.7 bar, 0.05% at 0.14-4 bar, 0.02% at 0.14-8 bar

**Hysteresis**  
 < 0.05% setting at mid-range outlet

**Sensitivity**  
 < 0.3 mbar / 0.05 psi

**Flow effect**  
 < 0.7 mbar / 0.01 psi

**Temperature effect**  
 < 1% change over full range -20 °C to 70 °C / -30 °F to 160 °F

**Temperature range**  
 -20°C to 70 °C / -4 °F to 160 °F

**Materials**  
 Zinc die-casting, passivated and epoxy painted, beryllium copper capsule, NBR (Buna N) diaphragm

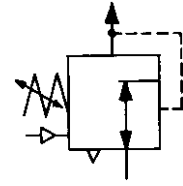

1/4" NPT, 280 l/min\*

### Adjusting by

Flow rate	Connection thread	Pressure range	Order number
l/min *	NPT	bar	

### Volume booster / differ. press. regulator

$K_v$ : 0.15 (m<sup>2</sup>/h) supply max. 10 bar

**53.20**

handwheel	280	1/4"	0.2 ...1 0.14...8	<b>53.2201.00</b> <b>53.2204.00</b>
tapped exhaust	280	1/4"	0.2 ...1 0.14...8	<b>53.2401.00</b> <b>53.2404.00</b>
screw	280	1/4"	0.2 ...1 0.14...8	<b>53.1901.00</b> <b>53.1904.00</b>
tapped exhaust	280	1/4"	0.2 ...1 0.14...8	<b>53.2101.00</b> <b>53.2104.00</b>

### Diaphragm repair kit

diaphragm	nozzle and flat-type gasket	0.2 ...1 0.14...8	<b>53.1000.95 R</b> <b>53.1000.98 R</b>
-----------	-----------------------------	----------------------	--



53.2204.00



53.1904.00

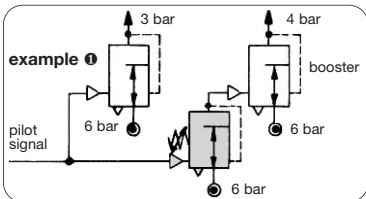

pressure difference  $P_1 - P_2 = \text{constant}$   
e.g. 1 bar

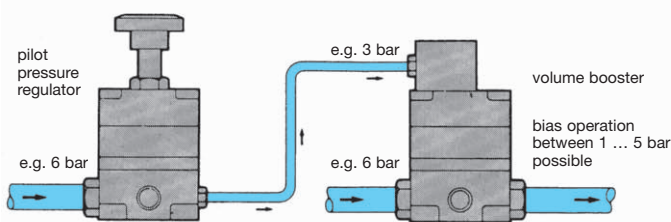
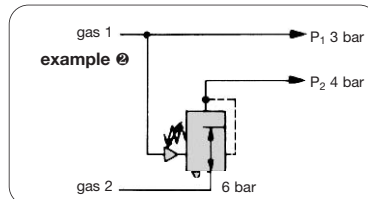

Control of volume booster

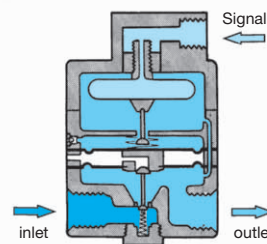

cross-section of booster

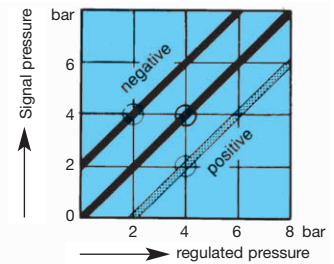

Bias adjustment

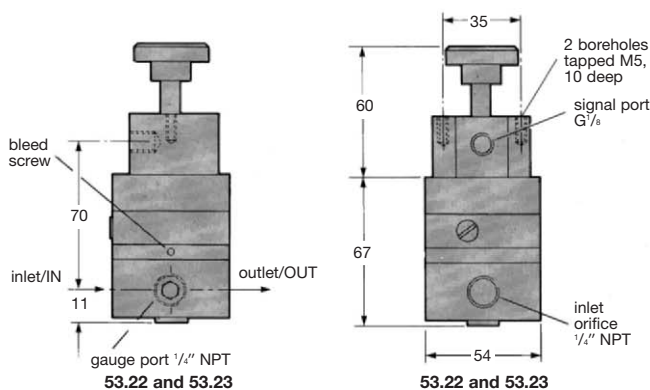

53.22 and 53.23

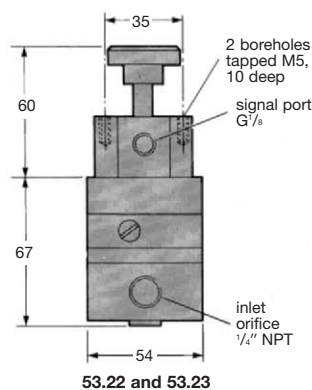

53.22 and 53.23

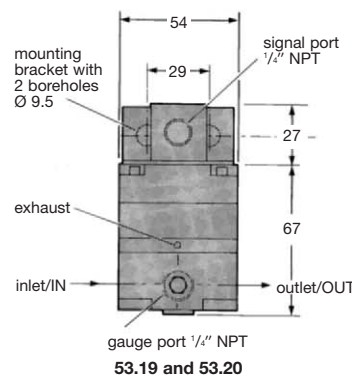

53.19 and 53.20

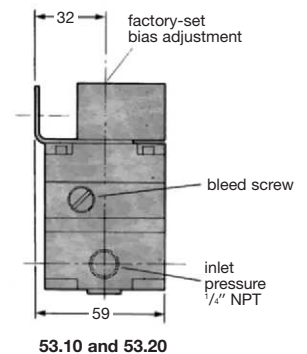

53.10 and 53.20

\*1 at 7 bar supply pressure and 1.4 bar outlet pressure

<b>For your information:</b>	1 bar: 14.8 psi	1 l/min: 0.035 scfm	1 mm: 0.039 inch	Pressure gauge: Please consult chapter "Gauges"
	1 psi: 0.069 bar	1 scfm: 28.3 l/min	1 inch: 25.4 mm	



**Order example:**  
53.2204.00