

Description	Solid-built and low-cost lubricator of zinc die-casting for compressed air. Lubrication is proportional to the flow rate. Two boreholes in the body for wall-mounting.		
Supply pressure	12 bar, 16 bar or 20 bar, depending on bowl		
Bowl	of polyurethane of zinc die-casting, with or without sight glass of brass	for G ¹ / ₈ to G ¹ / ₄ for G ³ / ₈ to G ¹ / ₂ for G ¹ / ₂ to G ²	12 bar 16/20 bar 20 bar
Temperature range	-10 °C to 50 °C / -14 °F to 130 °F in plastic bowl -20 °C to 60 °C / -4 °F to 140 °F in metal bowl		
Materials	Body: zinc die-casting aluminium SGALSI aluminium Al11S	G ¹ / ₈ to G ¹ / ₄ G ³ / ₈ to G ¹ / ₂ G ¹ / ₂ to G ²	

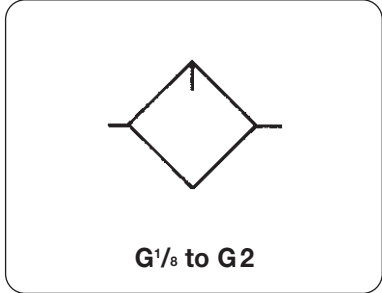

Dimensions			Bowl	Flow	Pressure	Connection	Order
H	B	C	design	rate	P ₁	thread	number
mm	mm	mm	*1	m ³ /h*2	max. bar	G	

Lubricator for compressed air LD

161	40	115	L	45	36	600	12	G ¹ / ₈	LD-01L
127	40	81	K	30	36	600	12		LD-01K
161	40	115	M	45	36	600	16		LD-01M
161	40	115	L	45	40	660	12	G ¹ / ₄	LD-02L
127	40	81	K	30	40	660	12		LD-02K
161	40	115	M	45	40	660	16		LD-02M
214	64	136	M	200	144	2400	16	G ³ / ₈	LD-03M
214	64	136	M	200	156	2600	16	G ¹ / ₂	LD-04M
249	90	169	M	500	420	7000	16	G ³ / ₄	LD-06M
249	90	169	M	500	480	8000	16	G ¹	LD-08M
249	150	169	M	500	540	9000	16	G ¹ / ₄	LD-10M
249	150	169	M	500	600	10000	16	G ¹ / ₂	LD-1AM
331	199	230	M	1500	1620	27000	16	G ¹ / ₂	LD-12M
331	199	230	N	1500	1620	27000	20	G ¹ / ₂	LD-12N
331	199	230	M	1500	1680	28000	16	G ²	LD-16M
331	199	230	N	1500	1680	28000	20	G ²	LD-16N



Special options add the appropriate letter

20 bar pressure	bowl w/o sight glass;	oil drip regulator of brass, from G ³ / ₈	N LD-... N
0.02 litre bowl	max. 12 bar,	of plastic	U LD-0... U
8 litre bowl	max. 20 bar,	of brass	Q LD-... Q
24 litre bowl	max. 20 bar,	of brass	S LD-... S

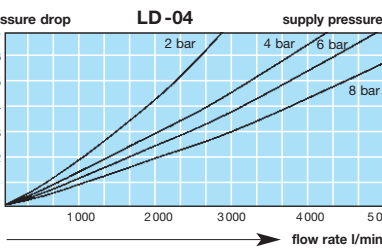
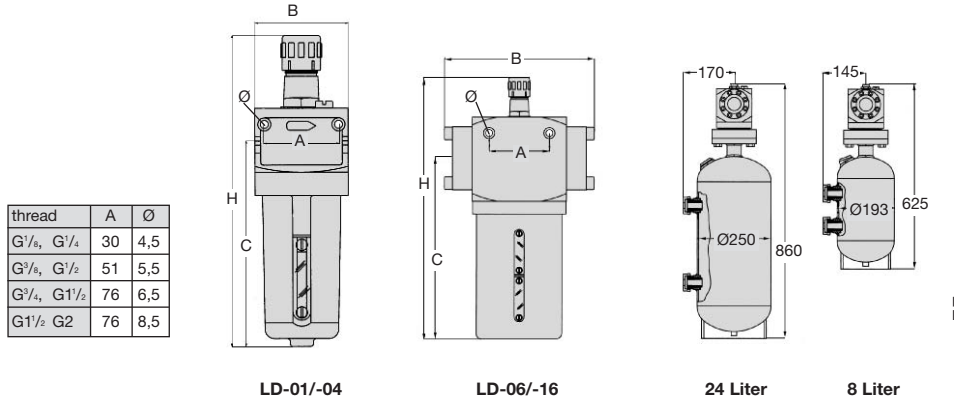

*1 K: plastic bowl
L: plastic bowl, long
M: metal bowl with sight glass
N: metal bowl without sight glass

*2 7 bar supply pressure und $\Delta p = 0,33$ bar

For your information:	1 bar: 14.5 psi 1 psi: 0.069 bar	1 l/min: 0.035 scfm 1 scfm: 28.3 l/min	1 mm: 0.039 inch 1 inch: 25.4 mm
------------------------------	-------------------------------------	---	-------------------------------------

Order example:
LD-02K